



Djons Spherical Bearings

Engineering manual



DJONS SPHERICAL BEARINGS

Djons Spherical Bearings include five series that can be applied in almost any application. A spherical bearings allow a bearing to operate with misalignment in the shaft. It permits both rotational movement as well as angular rotation.

Our spherical bearing parts are produced with Orkot®, making them maintenance free and suitable for dry and wet conditions. They are approved for both the food and marine industry.

DJONS SPHERICAL BEARINGS SERIES

Our five spherical bearing series are designed for high load and low speed conditions. All series include Orkot® components. The table below shows the differences between each of the series. Please see the product page for more detailed specifications.

Specifications	SB	SBBS	SBBS-W	SBB0	SBB0-W
Maintenance free	✓	✓	✓	✓	✓
Low friction	✓	✓	✓	✓	✓
Axial support	Seegerrings	Seegerrings	Seegerrings	Interference fit + axial support	Interference fit + axial support
Load capacity (Max. load at shaft size 100mm)	++ (818)	++ (872)	+++ (1031)	+ (650)	++ (804)
Material Outer race	1.4404	1.4404	1.4404	Orkot® TLMM	Orkot® TLMM (Split outer race)
Material Ball	Orkot® TLMM (Split ball)	Orkot® TLMM	Orkot® TLMM	1.4404	1.4404
Material Inner bush	n/a	1.4404	1.4404	Orkot® TLMM*	Orkot® TLMM*

* Orkot TXMM inner bush optional

Engineering service

Djons has a team of highly skilled engineers who can help you to find the best solution for your application. We advise which type of bearing is suitable; we adapt them to suit specific conditions or we customise bearing solutions to accommodate your specific requirements.

INSTALLATION RECOMMENDATION

All our Orkot® spherical bearings can be installed without the need of any special equipment. SBBS and SBBS-W are to be installed with a location fit on both the outside and inside diameter. The SB series has a location fit on its outside diameter and a free running fit on the inside diameter.

The SBBO and SBBO-W series are to be installed with an interference fit. This can be easily achieved with a workshop press for shaft diameters under 100mm. For installation of larger bearings of the SBBO and SBBO-W series, please contact Djons.

The following hardware tolerances are recommended for all our spherical bearings:

Housing bore : H7
Shaft diameter : h7 or g7

Shaft and housing material

The SB series bearings are successfully used with many different shaft materials, including hardened steel, stainless steel (i.e. 316 or Duplex), gunmetal, chrome plated steel, ceramic coated steel and nitrided surfaces.

All housings and shafts in contact with the 1.4404 parts of our bearings can be made of any suitable metal. Care must be taken for galvanic corrosion when combining stainless steel with e.g. carbon steels.

Shaft and housing finish

In general, normal machined surfaces are sufficient to accommodate the Djons spherical bearings and no special surface roughness is required. With the SB series, additional care must be taken with the shaft finish. As with this design the shaft rotates in the Orkot® bearing, a shaft roughness below Ra 0.8 µm is recommended.

ABOUT ORKOT®

Orkot® is a high-grade polymer composite material containing solid lubricants. Compared to metal bearings Orkot® offers many advantages. They are maintenance-free and accept shaft misalignment and edge loads even under most demanding circumstances. Orkot® material is certified and therefore approved to be used in a variety of industrial, food and marine applications.

Orkot® is a Trelleborg product. Djons is preferred supplier of Trelleborg., world leader in engineered polymer solutions.

Orkot® Benefits

- Maintenance free, no lubrication required
- Friction coefficient is constant even after standstill
- Accommodates long-term constant loads
- Load capability is comparable with metal spherical bearings
- Can be used in temperatures up to 130°C
- Suitable for maritime applications

CHOOSING A SPHERICAL BEARING FOR YOUR APPLICATION

The type of spherical bearings required depends on the position of the shaft and the movement in the application.

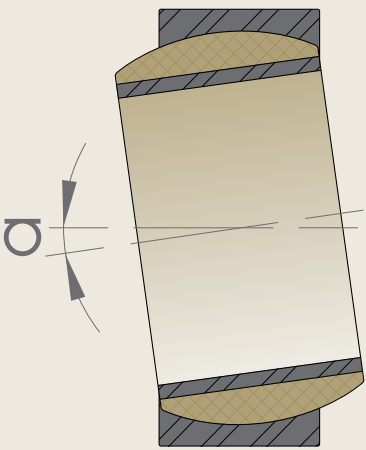
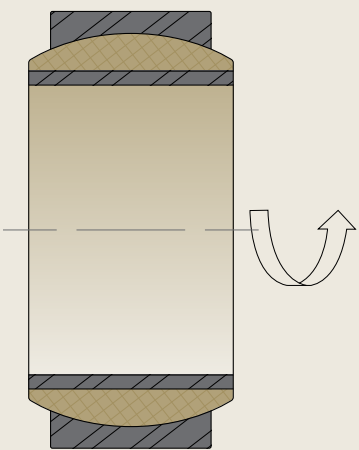
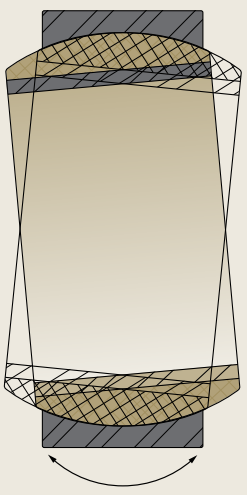
Misalignment of the shaft	Rotational movement	Sway movement
		
The static tilt angle between shaft and housing.	The dynamic rotation of the shaft around the longitudinal axis.	The dynamic rotation of the shaft around the transverse axis.

Which bearing suits your application?

The overview below provides a guideline to determine which bearing is required for your application. Please view the product page for technical specifications for each, and contact Djons for any questions you may have.

Position of the shaft	Movement		Bearing series
	Rotational	Swaying	
Is the tilt angle larger or smaller than 2°?	Rotational	Swaying	
Larger than 2°	Yes	Yes	SBB0
		No	SB
	No	Yes	SBB0
		No	SBBS
Smaller than 2°	Yes	Yes	SBB0-W
		No	SBB0-W
	No	Yes	SBB0-W
		No	SBBS-W

SB

The SB is generally chosen when the tilt angle of the shaft is more than 2°. The SB Series can be used for rotational movement but is not ideal for swaying movements. A split ball is more cost effective and does not affect the quality or lifetime of the bearing.

Specifications

Maintenance free	✓
Low friction	✓
Axial support	Seegerrings
Load capacity	++
Material Outer race	1.4404
Material Ball	Orkot TLMM (Split ball)
Material Inner bush	n/a

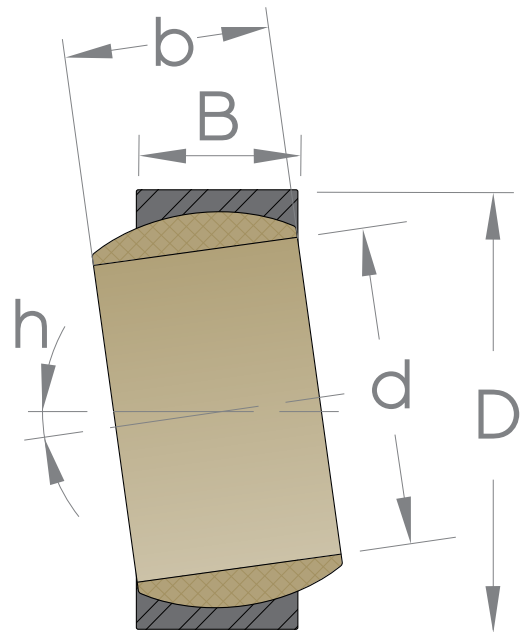

Technical specifications

	B mm	b mm	D mm	d mm	h °	dynamic load ×10 ³ N	static load ×10 ³ N
SB 20	12	16	35	20	9	21	42
SB 25	16	20	42	25	7	33	67
SB 30	18	22	47	30	6	44	88
SB 35	20	25	55	35	7	56	112
SB 40	22	28	62	40	7	69	139
SB 45	25	32	68	45	8	84	168
SB 50	28	35	75	50	7	104	208
SB 60	36	44	90	60	7	162	325
SB 70	40	49	105	70	7	211	422
SB 80	45	55	120	80	6	269	538
SB 90	50	60	130	90	6	331	661
SB 100	55	70	150	100	8	409	818
SB 110	55	70	160	110	7	443	886
SB 120	70	85	180	120	7	619	1239
SB 140	70	90	210	140	7	711	1421
SB 160	80	105	230	160	8	924	1848
SB 180	80	105	260	180	7	1013	2025
SB 200	100	130	290	200	8	1434	2869

SBBS

The SBBS is generally chosen when the tilt angle of the shaft is more than 2° and when there is no rotational and no swaying movement. It is a good solution for (semi-) static applications.

Specifications

Maintenance free	✓
Low friction	✓
Axial support	Seegerrings
Load capacity	++
Material Outer race	1.4404
Material Ball	Orkot TLMM
Material Inner bush	1.4404

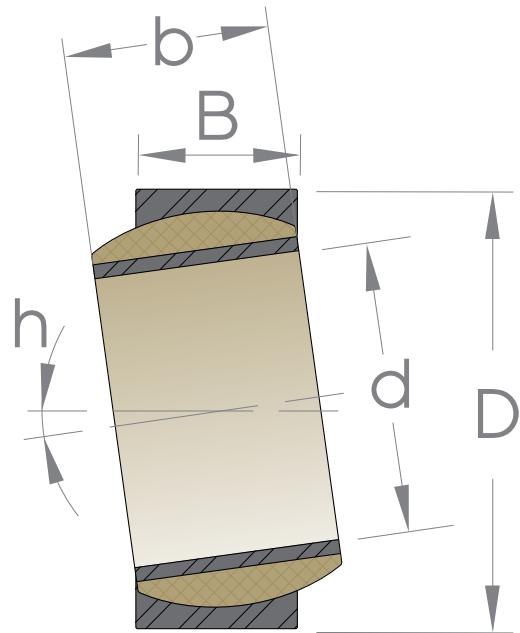

Technical specifications

	B mm	b mm	D mm	d mm	h °	dynamic load ×10 ³ N	static load ×10 ³ N
SBBS 30	18	22	47	30	6	45	90
SBBS 35	20	25	55	35	6	58	117
SBBS 40	22	28	62	40	7	72	144
SBBS 45	25	32	68	45	7	90	181
SBBS 50	28	35	75	50	7	113	225
SBBS 60	36	44	90	60	6	176	351
SBBS 70	40	49	105	70	6	221	442
SBBS 80	45	55	120	80	6	288	577
SBBS 90	50	60	130	90	5	352	705
SBBS 100	55	70	150	100	7	436	872
SBBS 110	55	70	160	110	7	470	940
SBBS 120	70	85	180	120	6	659	1317
SBBS 140	70	90	210	140	7	762	1525
SBBS 160	80	105	230	160	8	963	1927
SBBS 180	80	105	260	180	7	1072	2143
SBBS 200	100	130	290	200	7	1533	3066
SBBS 220	100	135	320	220	8	1668	3336
SBBS 240	100	140	340	240	8	1827	3654
SBBS 260	110	150	370	260	7	2191	4382
SBBS 280	120	155	400	280	6	2543	5086
SBBS 300	120	155	430	300	6	2719	5438

SBBS-W

The SBBS-W is generally chosen when the tilt angle of the shaft is smaller than 2° and when there is no rotational and no swaying movement. This bearing is preferred for static and semi-static applications. For dynamic applications, please take a look at our SBB0-W series

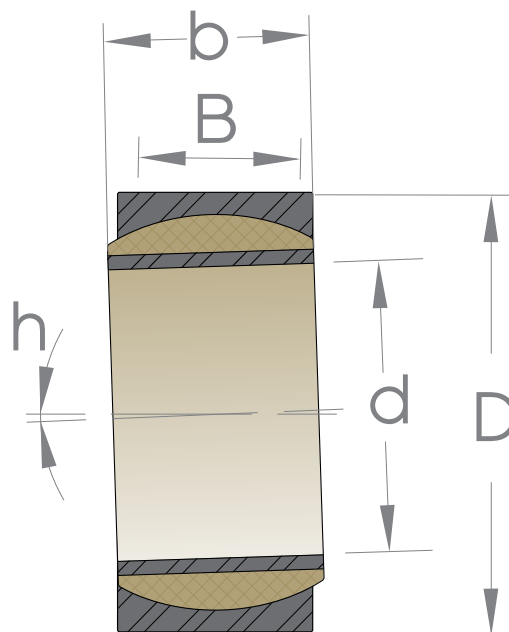

Specifications

Maintenance free	✓
Low friction	✓
Axial support	Seegerrings
Load capacity	+++
Material Outer race	1.4404
Material Ball	Orkot TLMM
Material Inner bush	1.4404

Technical specifications

	B mm	b mm	D mm	d mm	h °	dynamic load $\times 10^3$ N	static load $\times 10^3$ N
SBBS-W 100	67	71	150	100	2	515	1031
SBBS-W 110	74	78	160	110	2	619	1239
SBBS-W 120	80	85	180	120	2	735	1469
SBBS-W 140	95	100	210	140	2	1036	2072
SBBS-W 160	109	115	230	160	2	1309	2618
SBBS-W 180	122	128	260	180	2	1678	3356
SBBS-W 200	134	140	290	200	2	2044	4089
SBBS-W 220	148	155	320	220	2	2487	4973
SBBS-W 240	162	170	340	240	2	2941	5883
SBBS-W 260	175	185	370	260	2	3461	6921
SBBS-W 280	190	200	400	280	2	4072	8145
SBBS-W 300	200	212	430	300	2	4592	9183

SBBO

The SBBO is generally chosen when the angular misalignment of the shaft is larger than 2° and when there is a swaying movement, whether the shaft rotates or not. These bearings have to be installed with an interference fit. Fully axial support is required for these bearings. For detailed installation instructions, please get in touch.

Specifications

Maintenance free	✓
Low friction	✓
Axial support	Interference fit + axial support
Load capacity	+
Material Outer race	Orkot TLMM
Material Ball	1.4404
Material Inner bush	Orkot TLMM*

* Orkot TXMM inner bush optional

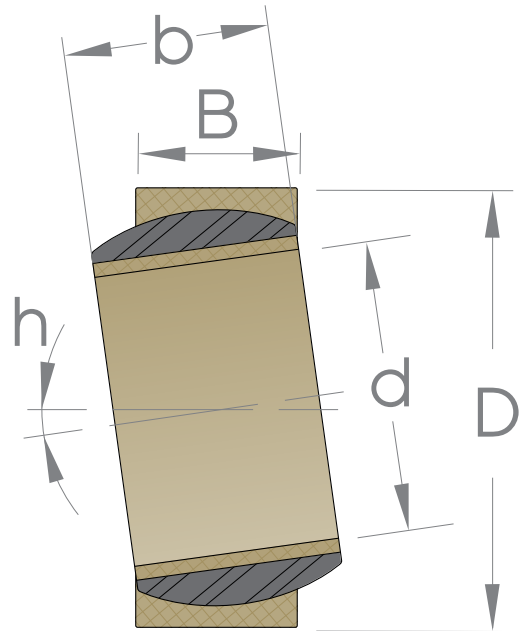

Technical specifications

	B mm	b mm	D mm	d mm	h °	dynamic load ×10 ³ N	static load ×10 ³ N
SBBO 30	18	22	47	30	6	32	65
SBBO 35	20	25	55	35	6	42	84
SBBO 40	22	28	62	40	7	53	106
SBBO 45	25	32	68	45	7	68	135
SBBO 50	28	35	75	50	7	84	168
SBBO 60	36	44	90	60	6	130	259
SBBO 70	40	49	105	70	6	168	336
SBBO 80	45	55	120	80	6	216	432
SBBO 90	50	60	130	90	5	270	540
SBBO 100	55	70	150	100	7	330	660
SBBO 110	55	70	160	110	7	363	726
SBBO 120	70	85	180	120	6	504	1008
SBBO 140	70	90	210	140	7	588	1176
SBBO 160	80	105	230	160	8	768	1536
SBBO 180	80	105	260	180	7	864	1728
SBBO 200	100	130	290	200	7	1200	2400
SBBO 220	100	135	320	220	8	1320	2640
SBBO 240	100	140	340	240	8	1440	2880
SBBO 260	110	150	370	260	7	1716	3432
SBBO 280	120	155	400	280	6	2016	4032
SBBO 300	120	155	430	300	6	2160	4320

SBBO-W

The SBBO is generally chosen when the angular misalignment of the shaft is smaller than 2° and when a) there is rotational movement – whether the shaft sways or not. Or b) there is no rotational movement, but the shaft does sway. These bearings have to be installed with an interference fit. Fully axial support is required for these bearings. Please contact Djons for detailed installation instructions.

Specifications

Maintenance free	✓
Low friction	✓
Axial support	Interference fit + axial support
Load capacity	++
Material Outer race	Orkot TLMM (Split outer race)
Material Ball	1.4404
Material Inner bush	Orkot TLMM*

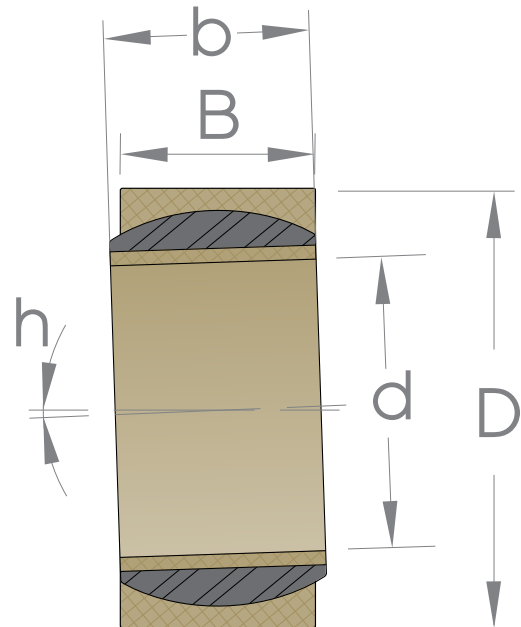

Technical specifications

	B mm	b mm	D mm	d mm	h °	dynamic load $\times 10^3$ N	static load $\times 10^3$ N
SBBO-W 100	67	71	150	100	2	402	804
SBBO-W 110	74	78	160	110	2	488	977
SBBO-W 120	80	85	180	120	2	576	1152
SBBO-W 140	95	100	210	140	2	798	1596
SBBO-W 160	109	115	230	160	2	1046	2093
SBBO-W 180	122	128	260	180	2	1318	2635
SBBO-W 200	134	140	290	200	2	1608	3216
SBBO-W 220	148	155	320	220	2	1954	3907
SBBO-W 240	162	170	340	240	2	2333	4666
SBBO-W 260	175	185	370	260	2	2730	5460
SBBO-W 280	190	200	400	280	2	3192	6384
SBBO-W 300	200	212	430	300	2	3600	7200

ABOUT DJONS

Contact Djons Engineering Team

Djons specialises in bearing and sealing solutions and is leading in the industry. Having almost 20 years of experience we provide complete bearing and sealing engineering projects. From calculation, design and production to installation.

Djons is preferred supplier from Trelleborg, world leader in engineered polymer solutions. This partnership means we work with the best materials available. We stock all these materials allowing us to deliver fast.

To complement our service we also specialise in Machining and Engineering Plastics. We serve a variety of customers locally and abroad for any type of job, big or small. We pride ourselves for our extensive technical knowledge allowing us to advise and deliver a solution for any application our customers can rely on.

Contact details

Djons B.V.
De Derde Hoeve 30
2676 CS Maasdijk
The Netherlands
Tel. +31 (0)174 540015
djons@djons.nl